



**SRI SAI RAM INSTITUTE OF TECHNOLOGY, CHENNAI-44**  
**Admn. Office, T. Nagar, Chennai – 17.**

No.19/SIT/TBM/29<sup>th</sup> Governing Body Meeting/2024

Dated: 24.05.2024

Sub: SIT, TBM - Administration – Organize 29<sup>th</sup> Governing Body Meeting in our College Campus – Permission – Granted.

Ref: Lr.No.63/S4/SSIT/Ch-44/2024, Dt: 23.05.2024 from the Principal – EOMS  
CODE: JA07-B.

**ORDER:**

The Principal has been permitted to organize **“29<sup>th</sup> GOVERNING BODY MEETING”** on **25.05.2024 (Saturday) @ 10.30 a.m.** in our College Campus – as requested in the reference cited.

For SRI SAI RAM INSTITUTE OF TECHNOLOGY,  
(Sd/xxxxxxx)

**CHIEF EXECUTIVE OFFICER**

/ By Order of Chief Executive Officer /

**EXECUTIVE DIRECTOR**

**To:**

– The Principal,  
Sri Sai Ram Institute of Technology,  
Chennai – 44.

– Chief Information Officer, SGI.

**Copy to:**

❖ Accounts Section.

*Copy to: Dean, Academic*



# SAI RAM INSTITUTE OF TECHNOLOGY

An Autonomous Institution | Affiliated to Anna University & Approved by AICTE, New Delhi  
Accredited by NBA and NAAC "A+" | An ISO 9001:2015 Certified and MHRD NIRF ranked institution  
Sai Leo Nagar, West Tambaram, Chennai - 600 044. [www.sairamit.edu.in](http://www.sairamit.edu.in)



EOMS CODE: JA07-B

Ref: T.O.No:63/S4/SSIT/Ch-44/ 2024

Date: 23.05.2024

Submitted to the Chairman

Sub: SSIT, Chennai – 44 – Conduct of Governing Body meeting on 25<sup>th</sup> May 2024 at 10.30 a.m. at SSIT.

\*\*\*\*\*

It is submitted that we have proposed to convene a 29<sup>th</sup> Governing Body Meeting at 10.30. a.m. on 25<sup>th</sup> May'2024 (Saturday) at Conference Room, First Floor of our Institution. A copy of the Agenda and Notice is enclosed herewith.

Submitted to the Chairman for kind perusal.

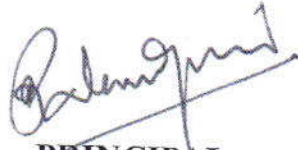
  
PRINCIPAL

Encl : as above

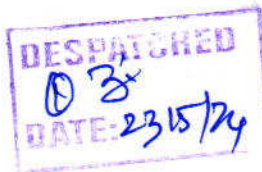



Sri  
**SAI RAM INSTITUTE OF TECHNOLOGY**

An Autonomous Institution | Affiliated to Anna University & Approved by AICTE, New Delhi  
Accredited by NBA and NAAC "A+" | An ISO 9001:2015 Certified and MHRD NIRF ranked institution  
Sai Leo Nagar, West Tambaram, Chennai - 600 044. [www.sairamit.edu.in](http://www.sairamit.edu.in)



NOTICE

SSIT,CH-44/GB/2024-29

Date : 23.05.2024

The 29<sup>th</sup> Governing Body meeting will be held at 10.30 a.m. on Saturday, 25<sup>th</sup> May,2024 in Conference Room (I Floor) at Sri Sai Ram Institute of Technology.

All the members are requested to attend the meeting as per their prior accepted mode.

TA & DA will be paid as per our norms. Kindly make it convenient to attend the meeting.

  
PRINCIPAL

PRINCIPAL  
SRI SAI RAM INSTITUTE OF TECHNOLOGY  
SAI LEO NAGAR, CHENNAI - 600 044.

Encl: Agenda

To:

All the Governing Body Members

Copy to :

Dr.S.Rajarajan, Dean (Academics)



# Sri SAI RAM INSTITUTE OF TECHNOLOGY

An Autonomous Institution | Affiliated to Anna University & Approved by AICTE, New Delhi  
Accredited by NBA and NAAC "A+" | An ISO 9001:2015 Certified and MHRD NIRF ranked institution  
Sai Leo Nagar, West Tambaram, Chennai - 600 044. [www.sairamit.edu.in](http://www.sairamit.edu.in)



## AGENDA

Agenda to be discussed in the Governing Body meeting is as follows:

- GB/2024.29.01 : Confirmation of Minutes of previous meeting and action taken report.
- GB/2024.29.02 : Program Curriculum & Teaching Learning Process.
- GB/2024.29.03 : Student Support & Progression
- GB/2024.29.04 : Infrastructure and E-Learning Resources
- GB/2024.29.05 : Research, Innovation & Industry Linkage
- GB/2024.29.06 : Quality Assurance & sustenance initiatives Ranking, Rating and Certifications
- GB/2024.29.07 : Governance and Administration
- GB/2024.29.08 : Institution Values, Extension and Social outreach activities
- GB/2024.29.09 : Any other matter with the permission of Chairman

Any other item discussed with the Chairman.

PRINCIPAL

PRINCIPAL

SRI SAI RAM INSTITUTE OF TECHNOLOGY  
SAI LEO NAGAR, CHENNAI - 600 044.



# Sri SAI RAM INSTITUTE OF TECHNOLOGY

An Autonomous Institution | Affiliated to Anna University & Approved by AICTE, New Delhi  
Accredited by NBA and NAAC 'A+' | An ISO 9001:2015 Certified and MHRD NIRF ranked institution  
Sai Leo Nagar, West Tambaram, Chennai - 600 044. [www.sairamit.edu.in](http://www.sairamit.edu.in)



## AGENDA

Agenda to be discussed in the Governing Body meeting is as follows:

- GB/2024.28.01 : Confirmation of Minutes of previous meeting and action taken report
- GB/2024.28.02 : Program Curriculum & Teaching Learning Process
- GB/2024.28.03 : Student Support & Progression
- GB/2024.28.04 : Infrastructure and E-Learning Resources
- GB/2024.28.05 : Research, Innovation & Industry Linkage
- GB/2024.28.06 : Quality Assurance & sustenance initiatives Ranking, Rating and Certifications
- GB/2024.28.07 : Governance and Administration
- GB/2024.28.08 : Institution Values, Extension and Social outreach activities
- GB/2024.28.09 : Any other matter with the permission of Chairman

Any other item discussed with the Chairman.

**PRINCIPAL**

**PRINCIPAL**  
SRI SAI RAM INSTITUTE OF TECHNOLOGY  
SAI LEO NAGAR, CHENNAI - 600 044.



# Sai SAI RAM INSTITUTE OF TECHNOLOGY

An Autonomous Institution | Affiliated to Anna University & Approved by AICTE, New Delhi  
Accredited by NBA and NAAC "A+" | An ISO 9001:2015 Certified and MHRD NIRF ranked Institution  
Sai Leo Nagar, West Tambaram, Chennai - 600 044. [www.sairamit.edu.in](http://www.sairamit.edu.in)



## GOVERNING BODY MEMBERS

S.No.	Name of the Member	Role	Signature
1	Dr.Sai Prakash Leo Muthu B.Tech., MBA CEO/Managing Trustee Sairam Group of Institutions Mobile No.9962077773 <a href="mailto:ceo@sairamgroup.in">ceo@sairamgroup.in</a>	Chairman	
2	Prof.Mukesh Mohania Dept. of CSE Indraprastha Institute of Info. Tech New Delhi. <a href="mailto:mukesh@iiitd.ac.in">mukesh@iiitd.ac.in</a>	UGC Nominee	
3	Dr.K.Parthiban Dept. of Mechanical Engineering Thanthai Periyar Govt. Institute of Technology, Vellore 632 002. <a href="mailto:kparthiban1970@gmail.com">kparthiban1970@gmail.com</a>	State Government Nominee	
4	Dr.D.Manamalli, Professor Dept. of Instrumentation Engg. M.I.T.Campus, Chennai 600 044. MobileNo.9445405689 <a href="mailto:manamalli_m@yahoo.com">manamalli_m@yahoo.com</a>	Anna Uni. Nominee	
5	Prof.Dr.R.Ramakrishnan Professor & Head, Dept. of Sports Technology Tamilnadu Physical Education and Sports University, Chennai. <a href="mailto:ramkinr@yahoo.com">ramkinr@yahoo.com</a>	Member/Academic	
6	Mr.J.Sujith Kumar, MSW HR/Location Head, Infosys Ltd. Chennai. Mobile No.9840892323 <a href="mailto:sujith.hr@gmail.com">sujith.hr@gmail.com</a>	Member/Industry	
7	Mr.B.Moorthi Trustee Sairam Group of Institutions Mobile No.9840447775 <a href="mailto:moorthi@sairamgroup.in">moorthi@sairamgroup.in</a>	Member	

on line

on line

on line



## SAI RAM INSTITUTE OF TECHNOLOGY

An Autonomous Institution | Affiliated to Anna University & Approved by AICTE, New Delhi  
Accredited by NBA and NAAC 'A+' | An ISO 9001:2015 Certified and MHRD NIRF ranked institution  
Sai Leo Nagar, West Tambaram, Chennai - 600 044. [www.sairamit.edu.in](http://www.sairamit.edu.in)



S.No.	Name of the Member	Role	Signature
8	Mr.K.Munusamy Trustee Sairam Group of Institutions Mobile No.9840052313 <a href="mailto:munusamy@sairamgroup.in">munusamy@sairamgroup.in</a>	Member	
9	Mr.R.Sathish Kumar Trustee Sairam Group of Institutions Mobile No.9840065530 <a href="mailto:sathish@sairamgroup.in">sathish@sairamgroup.in</a>	Member	
10	Mr.P.Balasubramanian Trustee Sairam Group of Institutions Mobile No.9789977778 <a href="mailto:balu@sairam.edu.in">balu@sairam.edu.in</a>	Member	
11	Mr.K.Naresh Raj Chief Information Officer Sairam Group of Institutions Mobile No.9962317377 <a href="mailto:cio@sairam.edu.in">cio@sairam.edu.in</a>	Member	
12	Mr.M.Sathyamoorthy, I.A.S(Retd.) Executive Director Sairam Group of Institutions Mobile No.9566113322	Member	
13	Mr.R.Palaniyandi, I.A.S(Retd.) Director-Quality Control Sairam Group of Institutions Mobile No.8925855455 <a href="mailto:palaniyandi@sairamit.edu.in">palaniyandi@sairamit.edu.in</a>	Member	
14	Dr.S.Rajarajan Professor, Dept. of ECE & Dean (Academics) Sri Sai Ram Institute of Technology Chennai 600 044. Mobile No.7708728553 <a href="mailto:deanacademic@sairamit.edu.in">deanacademic@sairamit.edu.in</a>	Member	
15	Dr.B.Sreedevi Professor and Head Dept. of CSE Sri Sai Ram Institute of Technology Chennai 600 044. Mobile No.8754582224 <a href="mailto:hodcse@sairamit.edu.in">hodcse@sairamit.edu.in</a>	Member	
16	Dr.K.Palanikumar Principal Sri Sai Ram Institute of Technology Mobile No.9677053338 <a href="mailto:principal@sairamit.edu.in">principal@sairamit.edu.in</a>	Ex-Officio &Member Secretary	



Sri

# SAI RAM INSTITUTE OF TECHNOLOGY

An Autonomous Institution | Affiliated to Anna University &amp; Approved by AICTE, New Delhi

Accredited by NBA and NAAC "A+" | BIS/EOMS ISO 21001 : 2018 and BVQI 9001 : 2015 Certified and NIRF ranked institution

Sai Leo Nagar, West Tambaram, Chennai - 600 044. [www.sairamit.edu.in](http://www.sairamit.edu.in)

## ACTION TAKEN REPORT OF THE 28<sup>TH</sup> GOVERNING COUNCIL MEETING HELD ON 17/08/2023.

S.No.	Item	Action Taken
1	<p>Curriculum, Syllabi and regulations for autonomous.</p> <p>a) Quality initiatives recommended by Academic Council and IQAC meetings for various academic and administrative activities.</p> <p>i) Categorize teachers' day awards with metrics. ii) Best department awards iii) Conduct of academic &amp; Curricula audit in association with NITTTR. iv) Redrafting of Course outcomes for the EVEN semester courses. v) Proposal to fix the number of credits for UG courses as not exceeding 170. vi) Transferring online Course credits to core courses.</p> <p>b) Quality Initiatives by IQAC i) NAAC sponsored a seminar on "Revised Accreditation Framework for quality enhancement to higher educational Institutes". ii) One day National level seminar on "NEP 2020 implementation using Change Management concepts in higher educational Institutes". c) Articulation of Course outcomes for the Odd and Even Semester courses. d) Review of the Results of the End Semester Examination. Number of admitted students TNEA cut off and Graduate Index, branch wise to the members. e) Centre for International Relations for Academic &amp; Research Collaboration.</p>	<p>(i) Teachers day is celebrated on 5<sup>th</sup> September, 2022. 19 awards given for individual faculty 4 awards for the department. Nominations obtained from the faculty and departments. (ii) Best department award bagged by ECE. (iii) Proposal obtained for curricula audit from NITTTR and approval sanction from the management. (iv) Course outcomes redrafted for all even semester courses. (v) Maximum number of credits fixed as 170 for all UG courses and placed in Academic Council for approval. (vi) Approval obtained from Academic Council for transferring online course credits to core courses and implemented from the even semester 2022-23.</p> <p>The committee accepted and approved.</p> <p>Events organized during 14.07.2021 &amp; 15.07.2021. Event organized during 21.04.2022. c) Teams formed to redraft course outcomes and workshops are</p>



	<p><b>The committee accepted and approved the information placed on curriculum, syllabi and regulations prepared for autonomous.</b></p>	<p>conducted for the faculty members.  d) The committee accepted and approved.  e) Following MoUs and partnership were signed to strengthen the International relationships.  i. The partnership with Universiti TEKNOLOGI PETRONAS.  II. MoU with SUR University College (Affiliated to BOND University – Australia Oman)  iii. Partnership with University of Saskatchewan, Canada.</p>
2	<p>Students Support and Progress</p> <ul style="list-style-type: none"> <li>a) Innovation Ecosystem</li> <li>b) SAIL App.</li> <li>c) Introduction of PGPA</li> <li>d) Project Guidelines</li> <li>e) Internship</li> <li>f) IEEE Xtreme competition</li> <li>g) Smart India Internal Hackathon 2022</li> <li>h) Sports activities</li> <li>i) Scholarships and freeships</li> <li>j) AICTE Entrepreneurship Development Cell (EDC) activities.</li> <li>k) Placement Highlights</li> <li>l) Alumni Association activities and establishment of Alumni chapters.</li> </ul> <p><b>The members accepted the information placed before them.</b></p>	<ul style="list-style-type: none"> <li>a) Web portal designed for Innovation Ecosystem in which the data related to the department wise projects with mapping to SDG will be uploaded.</li> <li>b) Students are encouraged to use the SAIL app and all the faculty to conduct tests using the SAIL app.</li> <li>c) Metric for PGPA framed and PGPA was calculated for the academic year 2021-22.</li> <li>d) A POSITIVE grading system followed to improve the quality of projects.</li> <li>e) LEAP-Learning Exposure, Action, Practice – The Internship Policy – Procedures and Policies Handbook for Regulation 2020 prepared.</li> <li>f) Appreciation accepted</li> <li>g) Appreciation accepted</li> <li>h) Congratulations accepted</li> <li>i) Information conveyed to the members was accepted</li> <li>j) Information conveyed to the members was accepted.</li> </ul>

		<p>k) Comparison presented to the members was accepted.</p> <p>l) Information conveyed to the members was accepted.</p>
3	<p>Infrastructure and e-learning resources</p> <p>a) New hostel building b) Yoga Center</p> <p><b>The members appreciated the progress on Infrastructure Planning and Monitoring.</b></p>	<p>a) Number of certificates received through IITB Nodal Center 11461.</p> <p>b) The new hostel building construction is in progress.</p> <p>c) Appreciations accepted for the celebration of International Yoga Day 4 programs conducted by the yoga club.</p>
4	<p><b>Research, Innovation &amp; Industry Linkages</b></p> <p>a) Strong industry alliances and Partnership through AICTE-Industry Institute Partnership (IIPC)</p> <p>b) Inculcation of research cultures through Sairam research clusters.</p> <p>c) Refereed Journal Publications &amp; Conference proceedings.</p> <p>d) IPR – Cell – Patents published and Granted.</p> <p>e) Submission of project proposal to various funding agencies (Government and Non-Government Organizations)</p> <p>f) Research Promotion Policy and Seed Money for projects.</p> <p>g) Sairam SDG Action Plan</p> <p>h) Recognized Research Supervisors</p> <p>i) Functional MoUs</p> <p>j) Startup Initiatives</p> <p>k) Establishment of Electronics CDAC IoT Research lab.</p> <p><b>The members appreciated and congratulated Research, Innovation and Industry linkage initiatives.</b></p>	<p>a) MoU signed with TIEMA and AIEMA. Training and Internships undergone by faculty and students.</p> <p>b) Research Activities encouraged by applying to funded projects.</p> <p>c) Quality Journal Publication under progress.</p> <p>d) Staff and students motivated for Patents and IP clinics conducted in the campus to encourage filing of patents.</p> <p>e) Information conveyed to the members was accepted.</p> <p>f) Students' projects are mapped with SDG action plans.</p> <p>g) Departments recognized as research center by AU</p> <p>a. Mechanical Engg</p> <p>b..PHYSICS (Proposed)</p> <p>i) Appreciation accepted</p> <p>j) Appreciation accepted.</p>
5	<p><b>Quality Assurance &amp; Sustenance initiatives Ranking Rating and Certifications</b></p> <p>a) Auditing cell – Academic &amp; Administrative</p> <p>b) AQAR 2020-21</p> <p>c) Extension of NBA (CSE, IT, Mech. EEE and ECE for continual Improvement.</p>	<p>a) Academic and Administrative Auditing Cell formed</p> <p>b) AQAR 2020-21 submitted</p> <p>c) Revised extension till 30.06.2025</p>

	<p>d) NBA Accreditation Process for MBA  e) Process of NAAC reaccreditation Second Cycle – IIQA &amp; SSR preparation process &amp; progress.  f) Recertification Audit Process for ISO 9001:2015  g) Initiatives for ISO 21000:2018 (EOMS) Standard Certification  h) Initiatives for QS-I-GAUGE Ratings  i) AICTE – Lilavati Award,</p> <p><b>The members accepted the information placed before them.</b></p>	<p>d) Under progress  e) Under process for submission of SSR  f) Recertification Certificate valid till 21.04.2024 and first surveillance audit conducted.  g) Under progress  h) Institutional Data submitted to QS IGAUGE for evaluation  i) Appreciation by the members accepted.</p>
6	<p><b>Governance and Administration</b>  a) Budget &amp; Financial Commitment  b) Sponsorship for NITTT registration and IEEE membership to faculty  c) Sponsorship to DUBAI expo  d) Sponsorship for change Management.</p> <p><b>The members congratulated the institution for the introduction of new courses and staff members for the sponsorship received.</b></p> <p><b>The members approved the process of interview and the recruitment for faculty positions.</b></p>	<p>a) Additional intake of 60 in CSE (180 to 240) department.  b) Faculty who completed 8 modules were appreciated and sponsored.  c) Appreciations accepted for Staff sponsored to DUBAI expo.</p> <p>Congratulations accepted.</p>
7	<p><b>CSR and other Extension Activities</b>  a) NSS and NCC  b) UBA and Club Activities  c) Club Activities – AICTE SPICES Grant  d) Green Practices at Sairam</p> <p><b>The members appreciated the AICTE SPICE grant.</b></p>	<p>a) Events organized in 2022-23 by  i) NCC – 25  ii) NSS – 20</p> <p>b) Appreciation accepted for events organized by UBA and Club-25  c) Events organized in 2022-23  By M app Club with the fund  d) Appreciation by the members accepted.  e) Appreciation by the members accepted.  f) Green initiative is continuing.</p>
8	Any other item with the permission of Chair	NIL

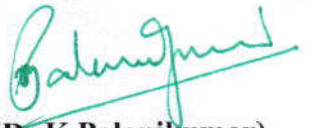
  
**(Dr.K.Palanikumar)**  
**PRINCIPAL**  
**PRINCIPAL**  
**SRI SAI RAM INSTITUTE OF TECHNOLOGY**  
**SRI LEO NAGAR, CHENNAI-600 044.**



# Sri SAI RAM INSTITUTE OF TECHNOLOGY

An Autonomous Institution | Affiliated to Anna University & Approved by AICTE, New Delhi  
Accredited by NBA and NAAC "A+" | An ISO 9001:2015 Certified and MHRD NIRF ranked institution  
Sai Leo Nagar, West Tambaram, Chennai - 600 044. [www.sairamit.edu.in](http://www.sairamit.edu.in)



Founder Chairman : MJF. Ln. Leo Muthu

**Dr.K.Palanikumar,M.E.,Ph.D.,**  
Principal

**Date: 24.06.2023**

## AGENDA FOR 6<sup>th</sup> ACADEMIC COUNCIL MEETING (By Circulation)

**AC.SEC.23.02.01:** To review and approve for the Formation of the Online Course Evaluation Committee (OCEC) for evaluating the online courses and to recommend the COE for the publication of results.

As per our Regulations (R2020), students must earn a minimum of 6 credits through online courses to qualify for the award of their degree. To ensure the accurate evaluation of marks/grades obtained by students in these online courses, it is proposed to form the Online Course Evaluation Committee (OCEC). The committee's primary responsibility will be to evaluate the marks/grades obtained by students and to provide recommendations to the COE office. The proposed Online Course Evaluation Committee comprising of the following members:

1. Principal — Chairman / Academic Council
2. Dean (Academics) — Member Secretary / Academic Council
3. BOS Chairman(s) of the department concerned — Members / Academic Council
4. Faculty Mentor(s) of the course
5. Year Coordinator(s) of the students concerned
6. Controller of Examinations (CoE)

**The item is placed before the committee for approval.**

**AC.SEC.23.02.2:** To review and approve the conduct of an End Semester Examinations (ESE) for the students opting online courses as part their credit transfer requirements for the award of the degree.

As per the Regulations (R2020) vide clause 12.4.1 it is required to provide the guidelines for the OCEC to evaluate the online courses opted by the students. Further, in order to maintain the academic rigor of our institution, it is proposed to conduct an End Semester Examination (ESE) for the online courses opted by the students.

To ensure fair evaluation, it is suggested that the marks obtained through online courses will be weighted for 50% (Internal), while the marks obtained from the ESE conducted by our COE will account for the remaining 50% (External). The final grading for each course will be determined following (vide clause 15.0 of R2020) our regular grading procedures.

The BoS of all the departments have recommended this for Academic Council approval.

**The item is placed before the committee for approval.**



  
**(Dr.K.Palanikumar)**  
**PRINCIPAL**  
**PRINCIPAL**  
SRI SAI RAM INSTITUTE OF TECHNOLOGY  
SAI LEO NAGAR, CHENNAI - 600 044.

BS



Admn Office : "SAI BHAVAN", #31 B, Madley Road, T. Nagar, Chennai - 600 017.  
Tel : 044 - 4226 7777 e-mail : [sairam@sairamgroup.in](mailto:sairam@sairamgroup.in)

 /SairamInstitutions

 +91 98843 45678



[www.sairamit.edu.in](http://www.sairamit.edu.in)



# Sri SAI RAM INSTITUTE OF TECHNOLOGY

An Autonomous Institution | Affiliated to Anna University & Approved by AICTE, New Delhi  
Accredited by NBA and NAAC "A+" | An ISO 9001:2015 Certified and MHRD NIRF ranked institution  
Sai Leo Nagar, West Tambaram, Chennai - 600 044. [www.sairamit.edu.in](http://www.sairamit.edu.in)



## MINUTES OF 6<sup>TH</sup> ACADEMIC COUNCIL AGENDA CIRCULATED ON 07.07.2023

The 6th Academic council (AC) meeting of Sri Sai Ram Institute of Technology was conducted on 07.07.2023 by circulating the agenda items to all External Academic council members. The members were,

**Dr.K.Palanikumar** **Chairman**  
Principal  
Sri Sai Ram Institute of Technology, West Tambaram  
Chennai

### EXTERNAL MEMBERS:

**Dr.K.Sankaranarayanan** **Senior Member**  
Director  
National Institute of Technology  
Puducherry  
Thiruvettakudy, Karaikal

**Dr.K.Sundareswaran** **University Nominee**  
Senior Professor  
Department of EEE  
National Institute of Technology  
Tiruchirappalli

**Prof.Banshidhar Majhi** **University Nominee**  
Vice Chancellor  
Veer Surendra Sai University of Technology,  
Burla, Sambalpur, Odisha,  
India. PIN:768018

**Prof.Dr.Sudhindra Nath panda** **University Nominee**  
Vice Chancellor  
C.V.Raman Global University  
Bidyanagar, Mahura, Janla  
Bhubaneswar – 752 054 (Odisha)

**Dr.I.A.Palani** **Member**  
Dean (Research & Development)  
Indian Institute of Technology Indore  
Khandwa Road, Simrol  
Indore

**Mr.Vasudevan Rajagopalan**  
Head-Talent Acquisition (India)  
Tata Consultancy Services  
Thoraipakkam, Chennai

**Member**

**Dr.R.Venkatesan**  
Adjunct Professor  
University of Massachusetts  
Dartmouth USA & IIT Bhubaneswar  
National Centre for Coastal Research,  
Ministry of Earth Sciences, NIOT Campus I,  
Chennai 600100.

**Member**

**INTERNAL MEMBERS**

**Dr.S.Rajarajan**  
Dean – Academics  
Sri Sai Ram Institute of Technology  
West Tambaram  
Chennai

**Member Secretary**

**Dr.G.Thamaraiselvi**  
Head of the Department  
Department of ECE  
Sri Sai Ram Institute of Technology  
West Tambaram  
Chennai

**Member**

**Dr.B.Sreedevi**  
Head of the Department  
Department of CSE  
Sri Sai Ram Institute of Technology  
West Tambaram  
Chennai

**Member**

**Dr.V.Brindhadevi**  
Head of the Department  
Department of IT  
Sri Sai Ram Institute of Technology  
West Tambaram  
Chennai

**Member**

**Dr.G.Prakash**  
Head of the Department  
Department of EEE  
Sri Sai Ram Institute of Technology  
West Tambaram  
Chennai

**Member**

**Dr.S.Murali**  
Head of the Department  
Department of Mechanical Engineering  
Sri Sai Ram Institute of Technology  
West Tambaram  
Chennai

**Member**

**Dr.G. Shanmugasundar**  
Dean (R&D)  
Sri Sai Ram Institute of Technology  
West Tambaram, Chennai.

**Member**

**Dr.C.R.Senthilnathan**  
Head of the Department  
Department of MBA  
Sri Sai Ram Institute of Technology  
West Tambaram  
Chennai

**Member**

**Dr.Rathika**  
Associate Professor  
Department of Chemistry  
Sri Sai Ram Institute of Technology  
West Tambaram  
Chennai

**Member**

**Mr.V.Balaji**  
Associate Professor  
Department of Mathematics  
Sri Sai Ram Institute of Technology  
West Tambaram  
Chennai

**Member**

-----  
**Agenda**

- AC.SIT.23.02.01:** To review and approve for the Formation of the Online Course Evaluation Committee (OCEC) for evaluating the online courses and to recommend the COE for the publication of results.
- AC.SIT.23.02.02:** To review and approve the conduct of an End Semester Examinations (ESE) for the students opting online courses as part their credit transfer requirements for the award of the degree.
- 

**AC.SIT.23.02.01:** To review and approve for the Formation of the Online Course Evaluation Committee (OCEC) for evaluating the online courses and to recommend the COE for the publication of results.

As per our Regulations (R2020), students must earn a minimum of 6 credits through online courses to qualify for the award of their degree. To ensure the accurate evaluation of marks/grades obtained by students in these online courses, it is proposed to form the Online Course Evaluation Committee (OCEC). The committee's primary responsibility will be to evaluate the marks/grades obtained by students and to provide recommendations to the COE office. The proposed Online Course Evaluation Committee comprising of the following members:

1. Principal — Chairman / Academic Council
2. Dean (Academics) — Member Secretary / Academic Council
3. BOS Chairman(s) of the department concerned — Members / Academic Council
4. Faculty Mentor(s) of the course
5. Year Coordinator(s) of the students concerned
6. Controller of Examinations (CoE)

**The item is placed before the committee for approval.**

**AC.SEC.23.02.2:** To review and approve the conduct of an End Semester Examinations (ESE) for the students opting online courses as part their credit transfer requirements for the award of the degree.

As per the Regulations (R2020) vide clause 12.4.1 it is required to provide the guidelines for the OCEC to evaluate the online courses opted by the students. Further, in order to maintain the academic rigor of our institution, it is proposed to conduct an End Semester Examination (ESE) for the online courses opted by the students.

To ensure fair evaluation, it is suggested that the marks obtained through online courses will be weighted for 50% (Internal), while the marks obtained from the ESE conducted by our COE will account for the remaining 50% (External). The final grading for each course will be determined following (vide clause 15.0 of R2020) our regular grading procedures.

The BoS of all the departments have recommended this for Academic Council approval.

**The item is placed before the committee for approval.**

-----

As this 6<sup>th</sup> Academic council interim meeting is planned to get the approval for the 2 points agenda, the agenda were circulated to the External Academic Council members through email. After going through the items and back & forth telephonic clarifications, all the external members have given their approval through email. The internal members were clarified by conducting meeting at Conference Room (I Floor). After deliberations, all the internal members understood and accepted the agenda items.

**Resolved to approve all the above agenda items and all the BoS Chairmen are directed to get ratification in their forthcoming 6<sup>th</sup> BoS meeting.**



## Request for Approval of Agenda Items - 6th Academic Council Meeting- by circulation- reg

14 messages

Rajarajan S &lt;deanacademic@sairamit.edu.in&gt;

Fri, Jul 7, 2023 at 9:39 AM

To: "Dr. I A Palani" <palaniia@iiti.ac.in>, "Dr.Banshidar Majhi" <bmnitrgmail.com>, "Dr.Banshidar Majhi" <vc@vssut.ac.in>, "Dr.K.Sundareswaran" <kse@nitt.edu>, "Dr.Panda VC" <vc@cgu-odisha.ac.in>, "Dr.Panda VC" <sudhindra.n.panda@gmail.com>, "Dr.R.Venkat NIOT" <dr.r.venkatesan@gmail.com>, "Dr.Sankaranarayananasamy" <ksnsamy@nitt.edu>, "Mr.Vasu TCS" <vasudevan.r@tcs.com>  
 Cc: "Mur. Dr. K. Palanikumar" <principal@sairamit.edu.in>

**Dear Academic Council Members,**

I hope this message finds you all in good health and high spirits. As per the requirements of Anna University, I would like to bring your attention to the attached agenda items that require your consideration and approval.

**I kindly request each council member to review the attached agenda items and send the approval through the same reply thread of this mail.**

The attached agenda items cover,

- 1.To review and approve for the Formation of the Online Course Evaluation Committee (OCEC) for evaluating the online courses and to recommend the COE for the publication of results.
- 2.To review and approve the conduct of an End Semester Examinations (ESE) for the students opting online courses as part their credit transfer requirements for the award of the degree.

Please review these agenda items and approve.

Thank you for your unwavering commitment to academic excellence and your dedication to the growth of our institution. I look forward to your reply.

Yours sincerely,



**Dr.S.Rajarajan**  
**Professor & Dean (Academics)**  
**Sri Sairam Institute of Technology, Chennai.**  
 7708728553

**AGENDA FOR 6th ACADEMIC COUNCIL MEETING (By Circulation).pdf**  
 584K

ksnsamy@nitt.edu &lt;ksnsamy@nitt.edu&gt;

Fri, Jul 7, 2023 at 9:52 AM

To: Rajarajan S &lt;deanacademic@sairamit.edu.in&gt;

Cc: "Dr. I A Palani" <palaniia@iiti.ac.in>, "Dr.Banshidar Majhi" <bmnitrgmail.com>, "Dr.Banshidar Majhi" <vc@vssut.ac.in>, "Dr.K.Sundareswaran" <kse@nitt.edu>, "Dr.Panda VC" <vc@cgu-odisha.ac.in>, "Dr.Panda VC" <sudhindra.n.panda@gmail.com>, "Dr.R.Venkat NIOT" <dr.r.venkatesan@gmail.com>, "Mr.Vasu TCS" <vasudevan.r@tcs.com>, "Mur. Dr. K. Palanikumar" <principal@sairamit.edu.in>

Dear Professor

The agenda item is approved from my end.  
 Thank you

K Sankaranarayananasamy

Quoting Rajarajan S <deanacademic@sairamit.edu.in>:

\*Dear Academic Council Members,\*

I hope this message finds you all in good health and high spirits. As per

the requirements of Anna University, I would like to bring your attention to the attached agenda items that require your consideration and approval.

\*I kindly request each council member to review the attached agenda items and send the approval through the same reply thread of this mail.\*

[Quoted text hidden]

--  
with warm regards,  
Dr. K. Sankaranarayananamy,  
Professor  
Department of Mechanical Engineering  
National Institute of Technology  
Tiruchirappalli - 620015  
Tamil Nadu, INDIA.  
Mobile: +91 9486001114  
Office: +91 431 25-3403  
Fax: +91 431 2500133

---

**Venkatesan** <dr.r.venkatesan@gmail.com>  
To: Rajarajan S <deanacademic@sairamit.edu.in>

Fri, Jul 7, 2023 at 10:20 AM

Approved

Regards  
Venkatesan  
[Quoted text hidden]

---

**Rajarajan S** <deanacademic@sairamit.edu.in>  
Draft

Fri, Jul 7, 2023 at 3:58 PM

[Quoted text hidden]

---

 **AGENDA FOR 6th ACADEMIC COUNCIL MEETING (By Circulation).pdf**  
584K

---

**Rajarajan S** <deanacademic@sairamit.edu.in>  
Draft To: kse@nitt.edu

Fri, Jul 7, 2023 at 4:01 PM

[Quoted text hidden]

Approved

Regards  
Venkatesan

Show quoted text

----- Forwarded message -----

From: **Rajarajan S** <deanacademic@sairamit.edu.in>  
Date: Fri, 7 Jul 2023, 09:39  
Subject: Request for Approval of Agenda Items - 6th Academic Council Meeting- by circulation- reg  
To: Dr. I A Palani <palaniia@iiti.ac.in>, Dr.Banshidar Majhi <bmnitrgmail.com>, Dr.Banshidar Majhi <vc@vssut.ac.in>, Dr.K.Sundareswaran <kse@nitt.edu>, Dr.Panda VC <vc@cgu-odisha.ac.in>, Dr.Panda VC <sudhindra.n.panda@gmail.com>, Dr.R.Venkat NIOT <dr.r.venkatesan@gmail.com>, Dr.Sankaranarayananasamy <ksnsamy@nitt.edu>, Mr.Vasu TCS <vasudevan.r@tcs.com>  
Cc: Mur. Dr. K. Palanikumar <principal@sairamit.edu.in>

[Quoted text hidden]

----- Forwarded message -----

From: **Rajarajan S** <deanacademic@sairamit.edu.in>  
Date: Fri, 7 Jul 2023, 09:39  
Subject: Request for Approval of Agenda Items - 6th Academic Council Meeting- by circulation- reg  
To: Dr. I A Palani <palaniia@iiti.ac.in>, Dr.Banshidar Majhi <bmnitrgmail.com>, Dr.Banshidar Majhi <vc@vssut.ac.in>, Dr.K.Sundareswaran <kse@nitt.edu>, Dr.Panda VC <vc@cgu-odisha.ac.in>, Dr.Panda VC <sudhindra.n.panda@gmail.com>, Dr.R.Venkat NIOT <dr.r.venkatesan@gmail.com>, Dr.Sankaranarayananasamy <ksnsamy@nitt.edu>, Mr.Vasu TCS <vasudevan.r@tcs.com>  
Cc: Mur. Dr. K. Palanikumar <principal@sairamit.edu.in>

[Quoted text hidden]

----- Forwarded message -----

From: **Rajarajan S** <deanacademic@sairamit.edu.in>

Date: Fri, 7 Jul 2023, 09:39

Subject: Request for Approval of Agenda Items - 6th Academic Council Meeting- by circulation- reg

To: Dr. I A Palani <palaniia@iiti.ac.in>, Dr.Banshidar Majhi <bmnitrgmail.com>, Dr.Banshidar Majhi <vc@vssut.ac.in>, Dr.K.Sundareswaran <kse@nitt.edu>, Dr.Panda VC <vc@cgu-odisha.ac.in>, Dr.Panda VC <sudhindra.n.panda@gmail.com>, Dr.R.Venkat NIOT <dr.r.venkatesan@gmail.com>, Dr.Sankaranarayananasamy <ksnsamy@nitt.edu>, Mr.Vasu TCS <vasudevan.r@tcs.com>

Cc: Mur. Dr. K. Palanikumar <principal@sairamit.edu.in>

[Quoted text hidden]

 **AGENDA FOR 6th ACADEMIC COUNCIL MEETING (By Circulation).pdf**  
584K

**Rajarajan S** <deanacademic@sairamit.edu.in>

Fri, Jul 7, 2023 at 4:02 PM

To: kse@nitt.edu

----- Forwarded message -----

From: **Rajarajan S** <deanacademic@sairamit.edu.in>

Date: Fri, 7 Jul 2023, 09:39

Subject: Request for Approval of Agenda Items - 6th Academic Council Meeting- by circulation- reg

To: Dr. I A Palani <palaniia@iiti.ac.in>, Dr.Banshidar Majhi <bmnitrgmail.com>, Dr.Banshidar Majhi <vc@vssut.ac.in>, Dr.K.Sundareswaran <kse@nitt.edu>, Dr.Panda VC <vc@cgu-odisha.ac.in>, Dr.Panda VC <sudhindra.n.panda@gmail.com>, Dr.R.Venkat NIOT <dr.r.venkatesan@gmail.com>, Dr.Sankaranarayananasamy <ksnsamy@nitt.edu>, Mr.Vasu TCS <vasudevan.r@tcs.com>

Cc: Mur. Dr. K. Palanikumar <principal@sairamit.edu.in>

[Quoted text hidden]

 **AGENDA FOR 6th ACADEMIC COUNCIL MEETING (By Circulation).pdf**  
584K

**kse@nitt.edu** <kse@nitt.edu>

Fri, Jul 7, 2023 at 4:08 PM

To: Rajarajan S <deanacademic@sairamit.edu.in>

I have approved.

Quoting Rajarajan S <deanacademic@sairamit.edu.in>:

----- Forwarded message -----

From: Rajarajan S <deanacademic@sairamit.edu.in>

Date: Fri, 7 Jul 2023, 09:39

Subject: Request for Approval of Agenda Items - 6th Academic Council Meeting- by circulation- reg

To: Dr. I A Palani <palaniia@iiti.ac.in>, Dr.Banshidar Majhi <bmnitrgmail.com>, Dr.Banshidar Majhi <vc@vssut.ac.in>, Dr.K.Sundareswaran <kse@nitt.edu>, Dr.Panda VC <vc@cgu-odisha.ac.in>, Dr.Panda VC <sudhindra.n.panda@gmail.com>, Dr.R.Venkat NIOT <dr.r.venkatesan@gmail.com>, Dr.Sankaranarayananasamy <ksnsamy@nitt.edu>, Mr.Vasu TCS <vasudevan.r@tcs.com>

Cc: Mur. Dr. K. Palanikumar <principal@sairamit.edu.in>

\*Dear Academic Council Members,\*

I hope this message finds you all in good health and high spirits. As per the requirements of Anna University, I would like to bring your attention to the attached agenda items that require your consideration and approval.

\*I kindly request each council member to review the attached agenda items and send the approval through the same reply thread of this mail.\*

[Quoted text hidden]

--

Dr. Sundareswaran K,  
Professor (HAG Scale),  
Department of Electrical and Electronics Engineering,  
National Institute of Technology-Trichy,  
Tiruchirappalli, Tamilnadu-620 015.  
India.

---

**Rajarajan S** <deanacademic@sairamit.edu.in>  
To: "Dr.K.Sundareswaran" <kse@nitt.edu>

Fri, Jul 7, 2023 at 4:12 PM

Thank you sir

[Quoted text hidden]

---

**Vasudevan Rajagopalan** <vasudevan.r@tcs.com>

Sat, Jul 8, 2023 at 11:09 AM

To: Rajarajan S <deanacademic@sairamit.edu.in>, "Dr. I A Palani" <palaniia@iiti.ac.in>, "Dr.Banshidar Majhi" <bmnitrgmail.com>, "Dr.Banshidar Majhi" <vc@vssut.ac.in>, "Dr.K.Sundareswaran" <kse@nitt.edu>, "Dr.Panda VC" <vc@cgu-odisha.ac.in>, "Dr.Panda VC" <sudhindra.n.panda@gmail.com>, "Dr.R.Venkat NIOT" <dr.r.venkatesan@gmail.com>, "Dr.Sankaranarayananasamy" <ksnsamy@nitt.edu>  
Cc: "Mur. Dr. K. Palanikumar" <principal@sairamit.edu.in>

TCS Confidential

Dear Sir,

Greetings to you.

I have gone through both the agenda items and details share and I recommend/ approve the same.

Thanks & Best regards,

Vasudevan R

Senior General Manager – HR

TATA Consultancy Services Ltd.

---

**From:** Rajarajan S <deanacademic@sairamit.edu.in>

**Sent:** Friday, 7 July 2023 12:10 pm

**To:** Dr. I A Palani <palaniia@iiti.ac.in>; Dr.Banshidar Majhi <bmnitrgmail.com>; Dr.Banshidar Majhi <vc@vssut.ac.in>; Dr.K.Sundareswaran <kse@nitt.edu>; Dr.Panda VC <vc@cgu-odisha.ac.in>; Dr.Panda VC <sudhindra.n.panda@gmail.com>; Dr.R.Venkat NIOT <dr.r.venkatesan@gmail.com>; Dr.Sankaranarayananasamy <ksnsamy@nitt.edu>; Vasudevan Rajagopalan <vasudevan.r@tcs.com>

**Cc:** Mur. Dr. K. Palanikumar <principal@sairamit.edu.in>

**Subject:** Request for Approval of Agenda Items - 6th Academic Council Meeting- by circulation- reg

"External email. Open with Caution"

[Quoted text hidden]



**Dr.S.Rajarajan**  
**Professor & Dean (Academics)**  
**Sri Sairam Institute of Technology, Chennai.**  
7708728553

TCS Confidential

=====  
Notice: The information contained in this e-mail message and/or attachments to it may contain confidential or privileged information. If you are not the intended recipient, any dissemination, use, review, distribution, printing or copying of the information contained in this e-mail message and/or attachments to it are strictly prohibited. If you have received this communication in error, please notify us by reply e-mail or telephone and immediately and permanently delete the message and any attachments. Thank you

**Rajarajan S** <deanacademic@sairamit.edu.in>  
To: Vasudevan Rajagopalan <vasudevan.r@tcs.com>

Wed, Jul 12, 2023 at 9:19 AM

Thank you Sir.



**Dr.S.Rajarajan**  
**Professor & Dean (Academics)**  
**Sri Sairam Institute of Technology, Chennai.**  
7708728553

[Quoted text hidden]

**Rajarajan S** <deanacademic@sairamit.edu.in>  
To: kse@nitt.edu

Wed, Jul 12, 2023 at 9:19 AM

Thank you Sir



**Dr.S.Rajarajan**  
**Professor & Dean (Academics)**  
**Sri Sairam Institute of Technology, Chennai.**  
7708728553

[Quoted text hidden]

**Rajarajan S** <deanacademic@sairamit.edu.in>  
To: Venkatesan <dr.r.venkatesan@gmail.com>

Wed, Jul 12, 2023 at 9:19 AM

Thank you Sir



**Dr.S.Rajarajan**  
**Professor & Dean (Academics)**  
**Sri Sairam Institute of Technology, Chennai.**  
7708728553

[Quoted text hidden]

**Rajarajan S** <deanacademic@sairamit.edu.in>  
To: ksnsamy@nitt.edu

Wed, Jul 12, 2023 at 9:20 AM

Thank you sir



**Dr.S.Rajarajan**  
**Professor & Dean (Academics)**  
**Sri Sairam Institute of Technology, Chennai.**  
📞 7708728553

[Quoted text hidden]

---

**Rajarajan S** <deanacademic@sairamit.edu.in>  
Draft

Fri, Jul 28, 2023 at 10:38 AM

----- Forwarded message -----

From: **Rajarajan S** <deanacademic@sairamit.edu.in>

Date: Fri, 7 Jul 2023, 09:39

Subject: Request for Approval of Agenda Items - 6th Academic Council Meeting- by circulation- reg

To: Dr. I A Palani &lt;palaniia@iiti.ac.in&gt;, Dr.Banshidar Majhi &lt;bmnitr@gmail.com&gt;, Dr.Banshidar Majhi &lt;vc@vssut.ac.in&gt;, Dr.K.Sundareswaran &lt;kse@nitt.edu&gt;, Dr.Panda VC &lt;vc@cgu-odisha.ac.in&gt;, Dr.Panda VC &lt;sudhindra.n.panda@gmail.com&gt;, Dr.R.Venkat NIOT &lt;dr.r.venkatesan@gmail.com&gt;, Dr.Sankaranarayananasamy &lt;ksnsamy@nitt.edu&gt;, Mr.Vasu TCS &lt;vasudevan.r@tcs.com&gt;

Cc: Mur. Dr. K. Palanikumar &lt;principal@sairamit.edu.in&gt;

[Quoted text hidden]



# Sri SAI RAM INSTITUTE OF TECHNOLOGY

An Autonomous Institution | Affiliated to Anna University & Approved by AICTE, New Delhi

Accredited by NBA and NAAC "A+" | An ISO 9001:2015 Certified and MHRD NIRF ranked institution

Sai Leo Nagar, West Tambaram, Chennai - 600 044. [www.sairamit.edu.in](http://www.sairamit.edu.in)



The following members were present during this 6<sup>th</sup> Academic Council meeting.

  
**(Dr.S.Rajarajan)**

Dean – Academics  
Sri Sai Ram Institute of Technology  
West Tambaram, Chennai

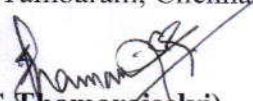
  
**(Dr.G.Phamaraiselvi)**

Head of the Department/ ECE  
Sri Sai Ram Institute of Technology  
West Tambaram, Chennai  
Head of the Department

  
**(Dr.B.Sreedevi)**

Department of CSE  
Sri Sai Ram Institute of Technology  
West Tambaram, Chennai.

  
**(Dr. V. Brindha Devi)**

Department of IT  
Head of the Department  
Sri Sai Ram Institute of Technology  
West Tambaram, Chennai

  
**(Dr.S.Murali)**

Head of the Department/  
IQAC Coordinator  
Department of Mechanical Engineering  
Sri Sai Ram Institute of Technology  
West Tambaram, Chennai

  
**(Dr.C.R.Senthilnathan)**

Head of the Department/MBA  
Sri Sai Ram Institute of Technology  
West Tambaram, Chennai.

  
**(Dr.Su.Suganthi)**

Head of the Department/AI&DS  
Sri Sai Ram Institute of Technology  
West Tambaram,  
Chennai

  
**(Dr.Rathika)**

Head of the Department (S&H)  
Department of Chemistry  
Sri Sai Ram Institute of Technology  
West Tambaram, Chennai

  
**(Dr.G. Shanmugasundar)**

Dean (R&D)  
Sri Sai Ram Institute of Technology  
West Tambaram, Chennai

  
**(Dr.G. Prakash)**

Head of the Department  
Department of EEE  
Sri Sai Ram Institute of Technology  
West Tambaram, Chennai.

  
**(Dr.M.Priya)**

Head of the Department/CCE  
Sri Sai Ram Institute of Technology  
West Tambaram  
Chennai

  
**(Mr.V.Balaji)**

Associate Professor  
Department of Mathematics  
Sri Sai Ram Institute of Technology  
West Tambaram, Chennai

  
**(Dr.K.Palanikumar)**

**Chairman (Academic Council)**

Principal  
Sri Sai Ram Institute of Technology  
West Tambaram, Chennai.





# Sri SAI RAM INSTITUTE OF TECHNOLOGY

An Autonomous Institution | Affiliated to Anna University & Approved by AICTE, New Delhi

Accredited by NBA and NAAC "A+" | An ISO 9001:2015 Certified and MHRD NIRF ranked institution

Sai Leo Nagar, West Tambaram, Chennai - 600 044. [www.sairamit.edu.in](http://www.sairamit.edu.in)



**SIT / CIRCULAR / 2023-24**

**Dated : 17.02.2024**

## CIRCULAR

### RESEARCH ETHICS COMMITTEE MEETING

The ethics committee meeting is Scheduled on 22.02.2024 at 10.00am in the conference hall – First floor with the members of research ethics committee, IIC members and the internal members of Research advisory Board to discuss the following agenda ,

1. RC-24-01: Review of the research projects proposal submitted.
2. RC-24-02: Review of Ideas submitted by the students for innovation eco systems.
3. RC-24-03 IPR – Cell activities.
4. RC-24-04 Faculty Publication and Patents Consolidated Review
5. RC-24-05 Planning of Institutions Innovation Activities ( IIC ) in line with MIC Calendar of events .

Principal

**PRINCIPAL**  
SRI SAI RAM INSTITUTE OF TECHNOLOGY  
SAI LEO NAGAR, CHENNAI - 600 044.



# Sri SAI RAM INSTITUTE OF TECHNOLOGY

An Autonomous Institution | Affiliated to Anna University & Approved by AICTE, New Delhi

Accredited by NBA and NAAC "A+" | An ISO 9001:2015 Certified and MHRD NIRF ranked institution

Sai Leo Nagar, West Tambaram, Chennai - 600 044. [www.sairamit.edu.in](http://www.sairamit.edu.in)



## ETHICS COMITEEE MEMBERS

Sl no	Name	Designation	Position
1	Dr.K.Palanikumar	Professor & Principal	Chairman
2	Dr.S. Rajarajan	Professor & Dean Academics	Member
3	Dr.Rene robin. C.R	Professor & Dean Innovation	Member
4	Dr.G.Shanmugasundar	Dean Research & Development	Convener
5	Viswesh .E	CEO / SVP LASER Pvt.LTD	External Member
6	Mr.Ramjawahar	Assistant Controller of Patents , Chennai	External Member
7	King Pragatheesh	SAP Consultant & Cyber Security	External Member
8	Mr.Gowthaman	Co-founder & CEO/ luxepic.com.	External Member
9	D.M Jayanthi	Director / BI world wide , Chennai	External Member
10	Dr.G.Thamaraiselvi	HOD/ECE	Member
11	Dr.S.Murali	HOD/Mech	Member
12	Dr.B.Sreedevi	HOD/CSE	Member
13	Dr.Brindha Devi V	HOD/IT	Member
14	Dr.G.Prakash	HOD/EEE	Member
15	Mr.V.Balaji	HOD/ S&H	Member
16	Dr.C.R Senthilnathan	HOD/ MBA	Member
17	Dr.Pachaiammal Priya	HOD/CCE	Member
18	Dr.Su.Suganthi	HOD/AI&DS	Member
19	Dr.Prabha	Associate Professor/ ECE	Member
20	Dr.S.Vigneshwaran	Assistant Professor/MECH	Member
21	Dr Vidya	Associate Professor/ CSE	Member
22	Dr .Arivazhagan .T	Asscoiate Professor/ S&H	Member
23	Dr.Sivarajeshwari	Associate Professor/ EEE	Member

  
Principal

PRINCIPAL  
SRI SAI RAM INSTITUTE OF TECHNOLOGY  
SAI LEO NAGAR, CHENNAI - 600 044.



# Sri SAI RAM INSTITUTE OF TECHNOLOGY

An Autonomous Institution | Affiliated to Anna University & Approved by AICTE, New Delhi  
Accredited by NBA and NAAC "A+" | An ISO 9001:2015 Certified and MHRD NIRF ranked institution  
Sai Leo Nagar, West Tambaram, Chennai - 600 044. [www.sairamit.edu.in](http://www.sairamit.edu.in)



## Minutes of the Ethics Committee Meeting

Date : 22/02/2024

Time 10.00 a.m

Venue : Conference Hall , First Floor

The minutes of the previous meeting held on 20.02.2023 was reviewed and approved by the members .

Agenda:

1. RC-24-01: Review of the research projects proposal submitted and status of sanctioned projects.
2. RC-24-02: Review of Ideas submitted by the students for yukti project Funding .
3. RC-24-03 IPR – Cell activities.
4. RC-24-04 Faculty Publication and Patents Consolidated Review
5. RC-24-05 Status of Anna university research department for Physics.

**Agenda: 01**

**The following proposals were reviewed and the status was discussed for further improvements,**

S.No	Project Title	Faculty Involved	Action Taken	Funding Agency identified
1	Breast cancer identification and classification using Software	Dr.K.Palanikumar & Dr.B.Sree Devi	Project Completion Status Reviewed	IGCAR – KALPAKKAM
2	Tamil nadu state council science and technology 2024 – student Funding projects through faculty guides	From All Departments	Recommended to submit each department must submit 10 Best students Innovations to this funding from Live in lab Projects	Tamil nadu state council science and technology

S.No	Project Title	Faculty Involved	Action Taken	Funding Agency identified
3	IEEE – EPIC Social Funding Projects	From All IEEE members	Recommended to submit minimum 05 Projects for funding from IEEE Faculty Members along with IEEE student members along with UBA Coordinators	IEEE – EPIC Funding
4	Harnessing Nature's Bounty: Fog Nets as a Sustainable Supplement to Water Scarcity in Arid Regions	Mrs. Roopa	Completion Status Reviewed	UBA – SEC Funding
5	Automated Tree Enumeration and Species Identification Using Machine Learning and High-Resolution Imagery for Sustainable Forest Management	Dr.Muthamizhan	Completion Status Reviewed	UBA – SEC Funding
6	Crop Monitoring and Plant diseases detection	Dr.Pachyammal Priya	Completion Status Reviewed	MSME – Funding
7	Electrical Converter for Industry applications	Dr.Dhansekar & Dr.Vijayaraja	Completion Status Reviewed	MSME – Funding

## MSME - Project Funding

**MSME Idea Hackathon 2.0**  
**Winners**



**D. JAESH**  
II YR - SIT OCE  
Theme : Digital Agriculture

**TITLE OF THE IDEA**  
Crop Monitoring and Diseases Detection

**₹. 14 Lakhs**



**S. KESAV SANADHAN**  
III YR - SIT EEE  
Theme : Digital Agriculture

**TITLE OF THE IDEA**  
Automated Portable Controller for Advancement of Smart Green System

**₹. 7 Lakhs**

भारत सरकार  
परमाणु ऊर्जा विभाग

GOVERNMENT OF INDIA  
DEPARTMENT OF ATOMIC ENERGY



सत्यमेव जयते

इन्दिरा गाँधी परमाणु अनुसंधान केंद्र  
कलपाक्कम 603 102 तमिल नाडु

INDIRA GANDHI CENTRE  
FOR ATOMIC RESEARCH  
KALPAKKAM 603 102 TAMILNADU

## Safety Quality and Resource Management Group

### WORK ORDER

No: IGCAR/SQRMG/RESD/RAMS/2023/08

6<sup>th</sup> October 2023

**To:**

Dr B. Sreedevi  
Professor & HOD (CSE)  
Sri Sai Ram Institute of Technology  
West Tambaram  
Chennai

**Sub:** Work Order for Development of GUI Platform towards Classification and Prediction of Breast Thermograms Based on Deep Learning Tools.

Your project proposal on Development of GUI Platform Towards Classification and Prediction of Breast Thermograms Based on Deep Learning Tools submitted has been accepted and on behalf of the President of India, for a total value including 18 % GST of Rs 17,13,400(Rupees Seventeen Lakhs Thirteen Thousand Four Hundred only) subject to terms and conditions given in Annexure 1.

**Scope of work:** To develop GUI platform and prediction of Breast Thermograms using Deep Learning Tools.

**Contract Period:** The contract is for a period of 24 months from the date of issue of WO.

**Terms of Payment:** Indicated in Annexure 1.

**Acknowledgement**

The receipt of the work order shall be acknowledged and your acceptance shall be communicated immediately.

Copy to  
Accounts Officer

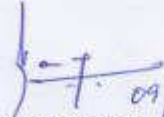
  
09/10/2023  
Director SQRMG

For and on behalf of President of India

**AGENDA: 02:**

The ideas submitted by the students for yukti funding status reviewed by the committee members also the committee appreciated the previous winners under the same funding .



**SAI RAM**  
 INSTITUTE OF TECHNOLOGY  
 Chennai - 600 044  
 RAISE FONG, THE GREAT INSTITUTE OF EDUCATION, nif, GOALS, GOV

**Congratulations!**  
 to the **TEAM GRINDER 2.0**

**AICTE & MIC**  
**YUKTI INNOVATION CHALLENGE**  
**WINNERS**

TOTAL SANCTIONED AMOUNT  
**₹ 5,00,000**

 <b>MR. D. PUSMGABA BANI</b> <small>GRADUATE PROFESSOR, IIC / IIT          Bengaluru, COIMBATUR I.I.T</small>	 <b>MR. M. DEVAPRASATH</b> <small>FINAL YEAR STUDENT, IIC / IIT          Tamil Nadu - COIMBATUR I.I.T</small>
 <b>MR. A. ABILAN</b> <small>FINAL YEAR STUDENT, IIC / IIT          Electronics, Tamil - COIMBATUR I.I.T</small>	 <b>MR. SATHYANAGAN KATHIRAMAN</b> <small>FINAL YEAR STUDENT, IIC / IIT          IIT, Tamil Nadu - COIMBATUR I.I.T</small>

IIC Coordinator: Dr.G.Shanmuga Sundar



**Dr. K. Palenikumar**  
Principal

**Dr. Sai Prakash LeoMuthu**  
Chairman & CEO



**SAI RAM**  
 INSTITUTE OF TECHNOLOGY  
 Chennai - 600 044  
 RAISE FONG, THE GREAT INSTITUTE OF EDUCATION, nif, GOALS, GOV

**DEPARTMENT OF INFORMATION TECHNOLOGY**  
**Congratulations!**  
 to the **TEAM AGRI CONNECT**

**AICTE & MIC**  
**YUKTI INNOVATION CHALLENGE**  
**WINNERS**

TOTAL SANCTIONED AMOUNT  
**₹ 2,00,000**

 <b>MR. J. SUTHANJAN</b> <small>ASSISTANT PROFESSOR, IIC / IIT          Tamil Nadu - Agri Connect</small>	 <b>MR. G. VINISH</b> <small>FINAL YEAR STUDENT, IIC / IIT          Tamil Nadu - Agri Connect</small>
 <b>MR. N. GOWDERAJAN</b> <small>FINAL YEAR STUDENT, IIC / IIT          Electronics, Tamil - Agri Connect</small>	 <b>MR. A. JAGADISHAN</b> <small>FINAL YEAR STUDENT, IIC / IIT          Electronics, Tamil - Agri Connect</small>

**AGRI CONNECT**  
SAI RAM INSTITUTE OF TECHNOLOGY

IIC Coordinator: Dr.G.Shanmuga Sundar



**Dr. K. Palenikumar**  
Principal

**Dr. Sai Prakash LeoMuthu**  
Chairman & CEO

Total Individuals  
Registered:  
**1146**

Total Innovations  
Submitted:  
**368**

Total Innovations  
Assigned:  
**325**

Total Innovations  
Verified:  
**202**

Total Innovations  
Recommended:  
**116**

Sr. No.	Innovation ID	Date of Submission	Innovation Title	FY of Development	Developed as part of	Team Lead Details	View Innovation Details	Verification	Avg. Score	Status	Nominate
1	IR2024-920505	22-09-2024	Coco Fiber- The Sustainable Agri-Bag TRL Title - TRL 4	2022-23	Independent Assignment/Non-academic Study Project	Budharaju Vinay ecopuls2023@gmail.com	<a href="#">View Details</a>	<a href="#">Assign - 0</a>		Pending	<a href="#">Nominate</a>
2	IR2024-920310	19-09-2024	Smart Accident Detector and Prevention System TRL Title - TRL 6	2023-24	Academic Requirement/Study Project	Sathasivan A st23ec087@sairamtao.edu.in	<a href="#">View Details</a>	<a href="#">Assign - 0</a>		Pending	<a href="#">Nominate</a>
3	IR2024-920309	19-09-2024	EEG(XI) TRL Title - TRL 4	2023-24	Academic Requirement/Study Project	SUBBIAH V st23ad055@sairamtap.edu.in	<a href="#">View Details</a>	<a href="#">Assign - 0</a>		Pending	<a href="#">Nominate</a>

Guidelines : [Application Submission - FAQ](#) | [VUBCT: National Innovation Repository - FAQ](#) | [YUJCTI-NIR: Orientation Session](#)

### AGENDA: 03:

The Students and Faculty innovation projects Converted as a Patent documents and we filled 21 patents in the year 2023 through IPR cell , other than that 03 patents was granted, These status were reviewed by the committee members .

**Highlight selected best Innovations & images with mention of inventor/innovation name for patents**







ENHANCING LEARNING THROUGH VR



BLIND WALKER



CASCADING OF AIR QUALITY DETECTOR AND DIGITAL DATA TRANSMISSION WITH ZERO ERROR IN MINIMUM DURATION



ADITI-A WOMEN SELF-DEFENCE SYSTEM USING IOT

**Recent Images of Agri connect**

The collage displays the Agri Connect web application. On the left is a login page with fields for 'Email' and 'Password', and a 'Sign In' button. Below it is a 'NEW HERE?' section for new users. The middle image shows a product discovery page with a search bar and a grid of product cards for items like 'Wheat', 'Rice', 'Soybean', and 'Banana'. The right image shows a dashboard with several data visualization charts, including a line graph for 'Production' and a pie chart for 'Sales'. At the bottom right, a mobile app interface is shown with a grid of product cards and a red circle highlighting a specific product card.

Youtube URL: <https://www.youtube.com/watch?v=mMD4oDfF2pE>

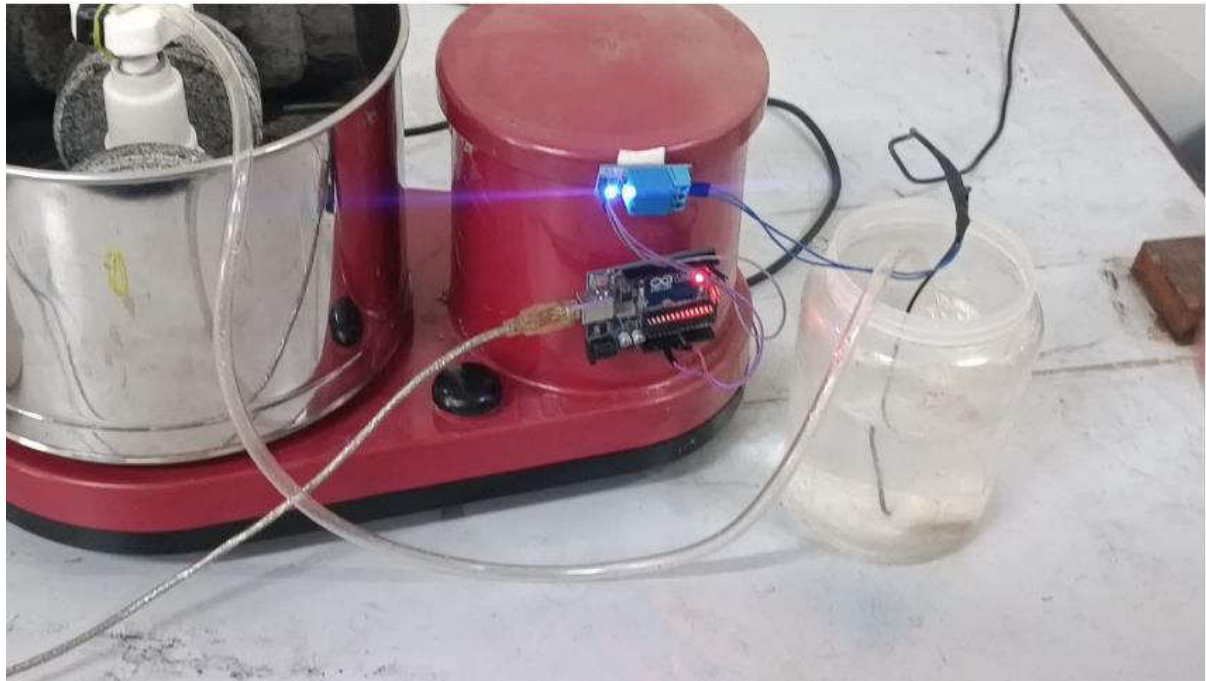

Automatic Wet Grinder

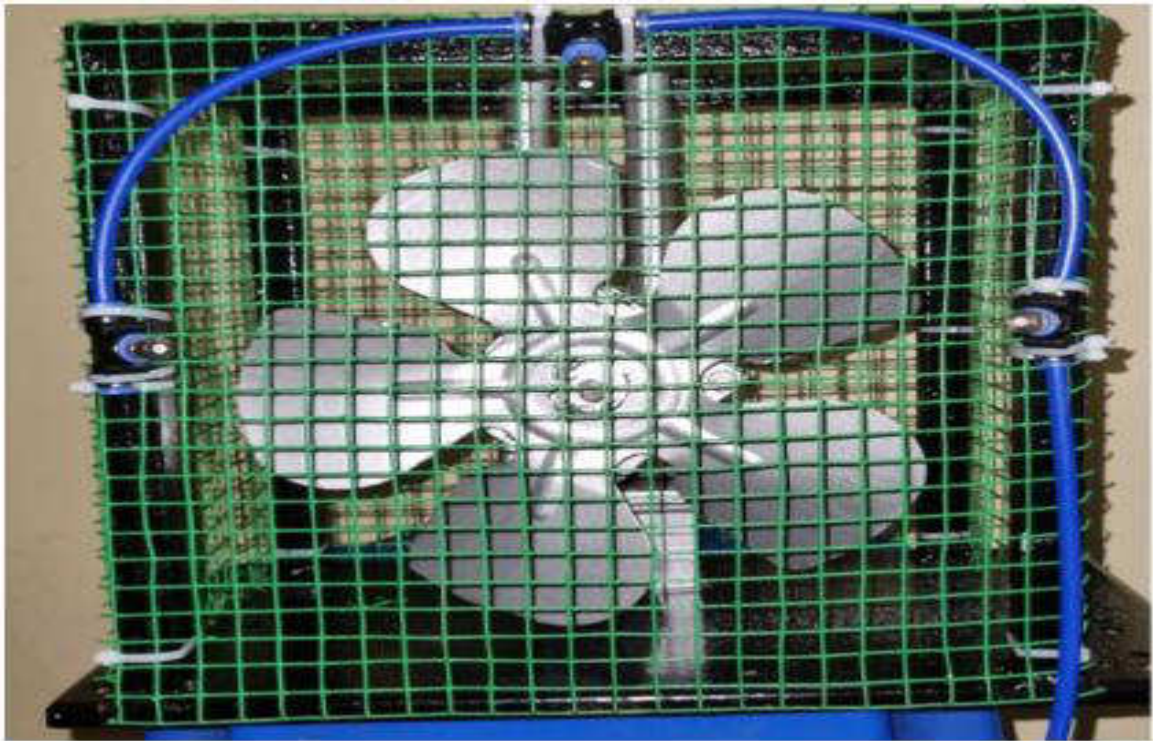
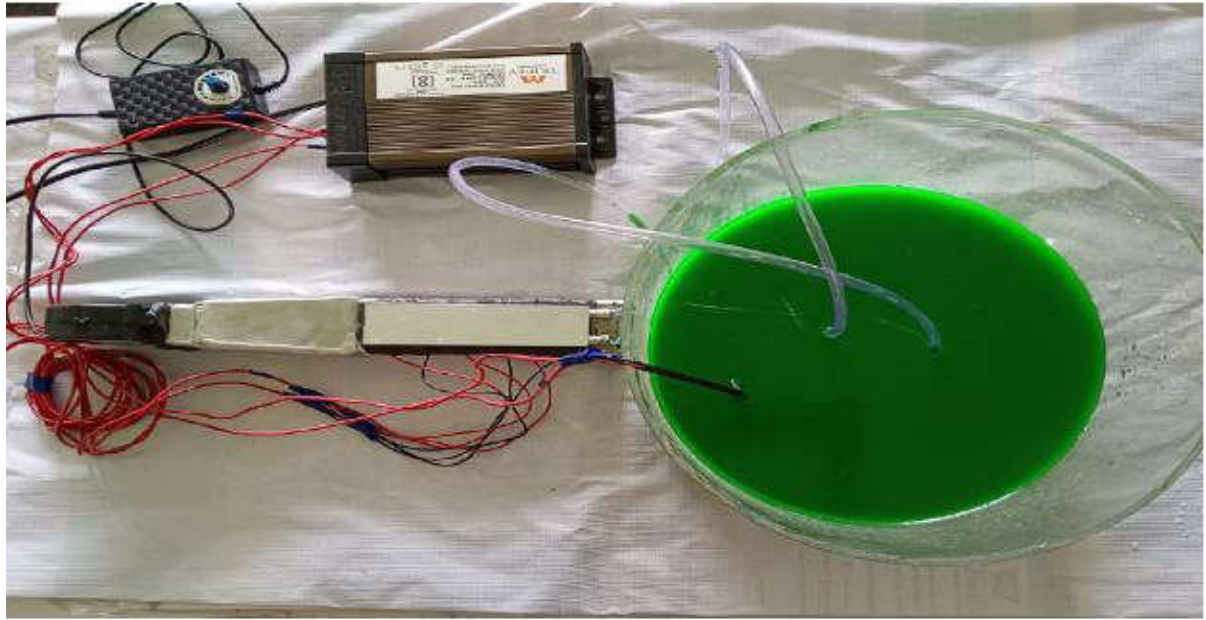
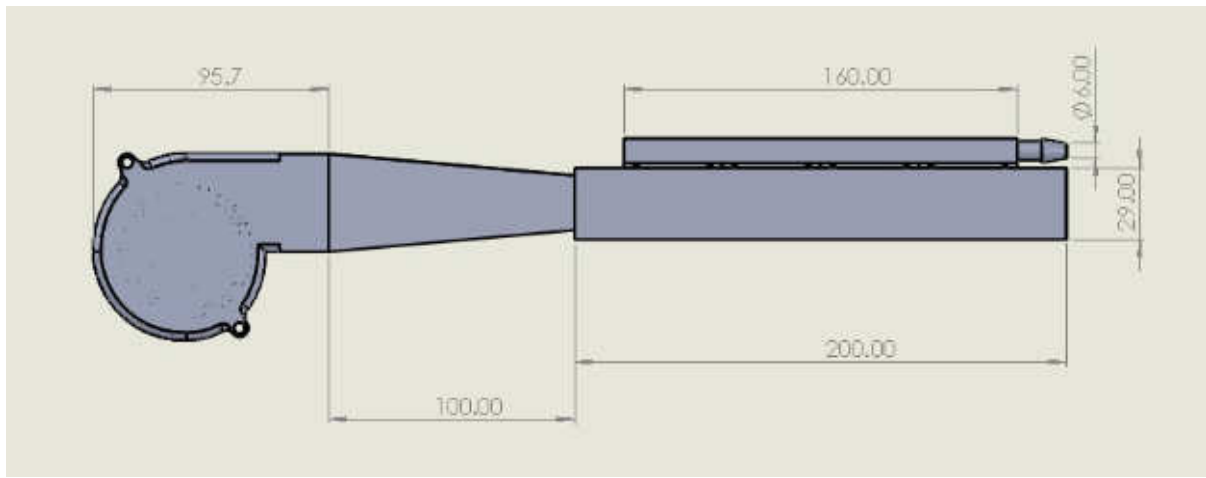



**Automatic Waste segregation Product**



क्रम सं/Sl No :044179079



पेटेंट कार्यालय, भारत सरकार | The Patent Office, Government Of India

पेटेंट प्रमाण पत्र | Patent Certificate

(पेटेंट नियमवली का नियम 74) | (Rule 74 of The Patents Rules)

पेटेंट सं. / Patent No. : 512496

आवेदन सं. / Application No. : 202141048478

फाइल करने की तारीख / Date of Filing : 25/10/2021

पेटेंटी / Patentee : 1.K. PALANIKUMAR 2.G. SHANMUGASUNDAR 3.A. PONSHANMUGAKUMAR 4.N. KIRUBAHARAN

प्रमाणित किया जाता है कि पेटेंटी को, उपरोक्त आवेदन में वधाप्रकरित A ROBOTIC DEVICE TO CLEAN TANKS/DRUMS नामक आविष्कार के लिए, पेटेंट अधिनियम, 1970 के उपबंधों के अनुसार आज तारीख अक्टूबर 2021 के पच्चीसवें दिन से बीस वर्ष की अवधि के लिए पेटेंट अनुदान किया गया है।

It is hereby certified that a patent has been granted to the patentee for an invention entitled A ROBOTIC DEVICE TO CLEAN TANKS/DRUMS as disclosed in the above mentioned application for the term of 20 years from the 25<sup>th</sup> day of October 2021 in accordance with the provisions of the Patents Act,1970.



Signature of Controller of Patents

अनुदान की तारीख : 20/02/2024  
Date of Grant :

ध्यान - इस पेटेंट के नवीकरण के लिए फीस, यदि इसे बनाए रखा जाना है, अक्टूबर 2023 के पच्चीसवें दिन को और उसके पचास प्रत्येक वर्ष में उन्नीस दिन देय होगी।  
Note. - The fees for renewal of this patent, if it is to be maintained, will fall / has fallen due on 25<sup>th</sup> day of October 2023 and on the same day in every year thereafter.

चूंकि पेटेंटी व आविष्कारकों की संख्या अधिक है, पेटेंटी व आविष्कारकों के नाम पृष्ठ संख्या 2 पर जारी है।  
\*Since the Number of Patentees / Inventors is more, the name of Patentees / Inventors are continued on Page No. 2

**AGENDA: 04:**

The quality publications by the faculty members in the year 2023 was presented in front of committee members and the committee members congratulated the faculty members and recommended for seed funding through SPACE.

The screenshot shows the Scopus search interface. The search query is "AF-ID ( 60109754 ) AND ( LIMIT-TO ( PUBYEAR, 2023 ) )". The results show 247 documents found. The first result is a retraction notice for an article in Optik (2023) 272, 170348, with 0 citations. The authors listed are Govindarajan, S., Mustafa, M.A., Kiyosov, S., and Naga Raju, M., Gola, K.K.

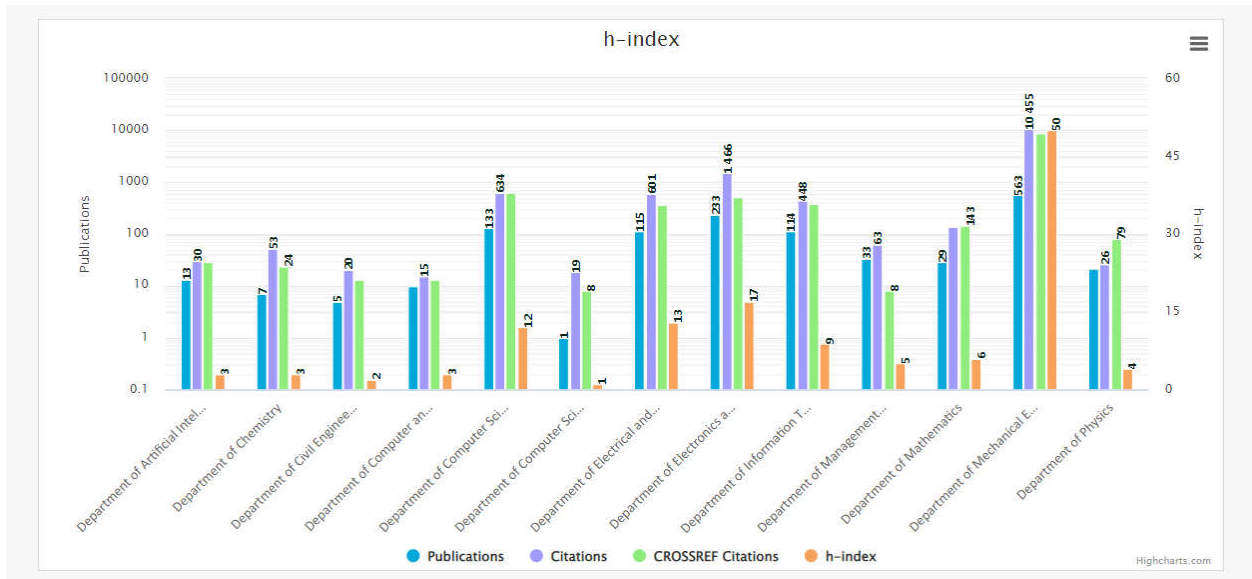



**Prof. K. Palanikumar, Ph.D**

Professor and Principal, Sri Sairam Institute of Technology  
Verified email at sairamit.edu.in

Machining composites artificial intelligence statistical analysis

[FOLLOW](#)

Cited by [VIEW ALL](#)

	All	Since 2019
Citations	15219	9353
h-index	65	47
i10-index	233	200

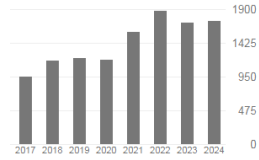

Public access [VIEW ALL](#)

0 articles	3 articles
not available	available

TITLE	CITED BY	YEAR
<a href="#">Mechanical property evaluation of sisal-jute-glass fiber reinforced polyester composites</a> KHR M Ramesh, K Palanikumar Composites Part B: Engineering 48, 1-9	894	2013
<a href="#">Plant fibre based bio-composites: Sustainable and renewable green materials</a> M Ramesh, K Palanikumar, KH Reddy Renewable and Sustainable Energy Reviews 79, 558-584	723	2017
<a href="#">Analysis of dry sliding wear behaviour of Al6061/SiC/Al2O3 hybrid metal matrix composites</a> K Umanath, K Palanikumar, ST Selvamani Composites Part B: Engineering 53, 159-168	396	2013
<a href="#">Comparative evaluation on properties of hybrid glass fiber-sisal/jute reinforced epoxy composites</a> M Ramesh, K Palanikumar, KH Reddy Procedia Engineering 51, 745-750	377	2013

**AGENDA: 05:**

The application (App. No.:16IR2606) of the Research recognition for the Department of Physics submitted to Annuniversity for approval was reviewed by the committee members. Also reviewed for present research center of mechanical engineering progress.

Total Institute research supervisors = 15







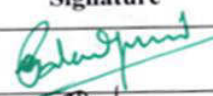

Total Full time research Scholar - 01

Total Part time research scholars = 05

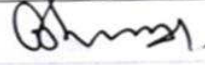
The above Scholars Ph.D status also reviewed by the Committee members .

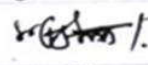
REF. NO	SUP. NAME	DEPARTMENT	COLLEGE/ORGANISATION	RESEARCH AREA	EMAIL
3020031	Murali S	Department of Mechanical Engineering	Sri Sairam Institute of Technology, Chennai-600044	Manufacturing, Industrial Engineering, Operations Management, Materials Processing	muralevels@gmail.com
8620300	Palanikumar K	Dept. of Mechanical Engg.	Sri Sairam Institute of Technology, Chennai	Machining Composites Modeling, Optimization, Soft Computing Applications in Manufacturing	palanikumar_k@yahoo.com
4320025	Sathish Kumar D	Department of Mechanical Engineering	Sri Sairam Institute of Technology West Tambaram, Chennai-600044	Heat Transfer Enhancement, Electronic Cooling, Heat Exchangers, Thermal Engineering	sathishd2688@gmail.com
4220043	Shanmugasundar G	Department of Mechanical Engineering	Sri Sai Ram Institute of Technology West Tambaram, Chennai-600044	Robotics, Optimization Techniques in Machining	shanmugasundar.mech@sairamit.edu.in
4120166	Velavan K	Department of Mechanical Engineering	Sri Sairam Institute of Technology West Tambaram, Chennai-600044	Composite Materials, Machining of Composites, Manufacturing	velavan.me@gmail.com
3720002	Vigneswaran R	Mechanical Engineering	Sri Sairam Institute of Technology Chennai-600044	Internal Combustion Engines, Alternate Fuels, Automobile Engineering	rvn.vignesh@gmail.com

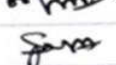
2940015	Saravanan P	Department of Information Technology	Sri Sai Ram Institute of Technology, Chennai-600044	Networks, Image Processing	saravanan.it@sairamit.edu.in
3370039	Arivazhagan T	Department of Physics	Sri Sai Ram Institute of Technology, West Tambaram, Kancheepuram	Crystal Growth, Nanomaterials, Solar Cells, Spectroscopy	arivazhagantt@gmail.com
2770032	Kumar M	Department of Chemistry	Sri Sai Ram Institute of Technology, Chennai	Polymer Composites, Polymer Membrane, Nano Material, Orgnaometallics, Photo catalyst and Hydrogen Production	kumarmk001@yahoo.com
4170048	Niruban Bharathi R	Department of Physics	SRI SAIRAM INSTITUTE OF TECHNOLOGY, CHENNAI, Chennai	Oxide Nanoparticles, Magnetism and Magnetic Materials, Spintronics Application and Nanomaterials	nirubanphd@gmail.com
4170145	Paul D	Department of Mathematics	Sri Sairam Institute of Technology West Tambaram, Chennai-600044	Graph Theory, Theoretical Chemistry, Theoretical Computer Science	paul.d.joe@gmail.com
4270028	Pitchaimani J	Department of Chemistry	Sri Sai Ram Institute of Technology West Tambaram, Chennai-600044	Catalysis, Opto Electronics, Material Science, Bioinorganic Chemistry	pitchumani07@gmail.com
2970010	Rajasekaran R	Department of Physics	Sri Sairam Institute of Technology, West Tambaram, Kancheepuram	Biophotonics, Spectroscopy	raj.shekar29@gmail.com
4170118	Saravanan K	Department of Physics	Sri Sai ram institute of technology, West tambaram, Chennai	Materials Science, Semi Conductors, Thin Films, Energy Storage and Conversion	kgsaranphy@gmail.com
4170039	Viswanathan E	Department of Physics	Sri Sairam Institute of Technology, West	Computational Materials Science	viswa.gently000@gmail.com

S.No	Name	Designation / Department	Signature
1	Dr.K.PALANIKUMAR	Principal	
2	Dr. S.Rajarajan	Dean Academics	
3	Dr.G.Shanmugasundar	Dean R&D	
4	Dr.S.Rathika	Coordinator / IQAC	
5	Dr.Sivarajeswari	AP/ EEE	
6	Dr.Prabha	AP/ECE	
7	Dr. Antony Rosewelt	AP/CSE	
8	Dr.Vigneswaran .R	AP/MECH	
9	Mrs. Sathya	AP/AI&DS	
10	Mrs. Kannaki	AP/CCE	

  
Principal

**PRINCIPAL**  
SRI SAI RAM INSTITUTE OF TECHNOLOGY  
SAI LEO NAGAR, CHENNAI - 600 044.